

9xK26WS-EPIWRC(K) / RCN.10

# Complast 9/9xK26WS

9 outer compacted strands, plastic impregnation

**Complast 9/9xK26WS** is a high-performance rope with compacted strands and plastic impregnation for all heavy duty hoisting applications including mobile cranes, tower cranes, crawler cranes, offshore cranes, deck cranes, cargo cranes, foundation cranes and harbour cranes.

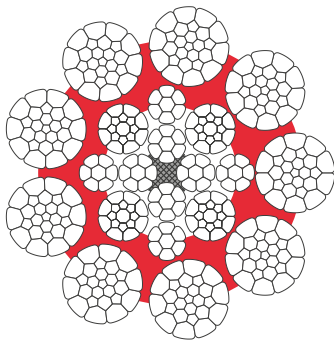

## Features:

- › 9 outer strands, compacted strands
- › Warrington core
- › Bright or galvanised steel wires
- › High cross-sectional metallic area

Complast 9/9xK26WS/2018/v1.0

Diameter		Section	Mass	Minimum breaking load	
mm	inch	mm <sup>2</sup>	kg/m	kN 1960 MPa	kN 2160 MPa
20	-	213.5	1.92	346	375
22	7/8	255.2	2.31	416	450
24	-	303.1	2.74	493	534
25	-	334.1	3.02	545	586
25.4	-	350.3	3.17	569	611
26	-	362.7	3.28	592	631
28	1-1/8	415.6	3.75	677	721
28.6	-	430.3	3.89	700	746
30	-	469.9	4.25	763	814
32	1-1/4	534.6	4.84	868	926
			<b>f - Fill Factor</b>	<b>k - Spinning Loss Factor</b>	
			0.675	0.830	0.815

**Please note:** Other diameters with other tolerances than those shown here can be made on studies.

**⚠ Never use with swivel**

Indicative values - Tolerance on diameter: ArcelorMittal design (0; +4%)

## Applications

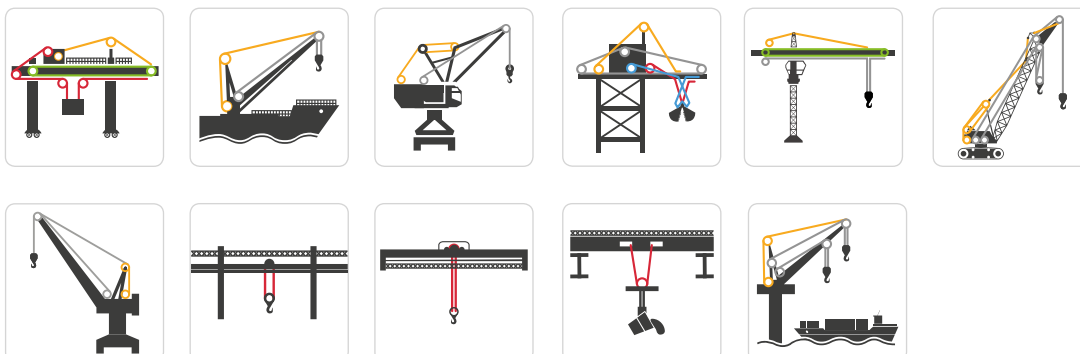

### KEY

- Hoist
- Trolley
- Boom Luffing
- Grab
- Auxiliary Hoist
- Pipe Handling

## Complast 9 wire rope properties

 <p><b>Lubrication</b></p> <p>Extends the life and increases rope performance.</p>	 <p><b>Bending Fatigue Resistance</b></p> <p>Ropes designed to cope with bending repeatedly under stress.</p>	 <p><b>Plastic Impregnation</b></p> <p>Thermoplastic sealing of inner core reducing friction.</p>	 <p><b>Compaction</b></p> <p>Smoothen outer surface with increased strength and reduced wear.</p>	 <p><b>High Breaking Resistance</b></p> <p>Ropes featuring a high breaking force.</p>	 <p><b>Resistance to Crushing</b></p> <p>Ropes designed to withstand or resist external forces.</p>	 <p><b>Regular Lay Rope</b></p> <p>Less core sensitivity with a non-rotational property.</p>	 <p><b>Lang Lay Rope</b></p> <p>Increased wear resistance and flexibility.</p>
---	--	--	--	--	--	---	---

## Storage and maintenance

The rope must be adequately maintained and regularly lubricated, as often as it is necessary, but at least when the rope works in extreme conditions and before/after prolonged inactivity. The lubricant must be compatible with the original grease. Before re-lubrication, the wire rope must be dry and cleaned by scraping. Cleaning by cloth, cryogenic spray, high pressure cleaner and solvents are forbidden.

When stored, the rope should be kept in a dry and ventilated environment with no direct contact with the floor and an air flow under the reel. Visual inspection is necessary before the use of a stored wire rope. In case of doubt of the quality of the wire rope, we can help you to find and make additional inspection analysis.

## EWRIS handling recommendations

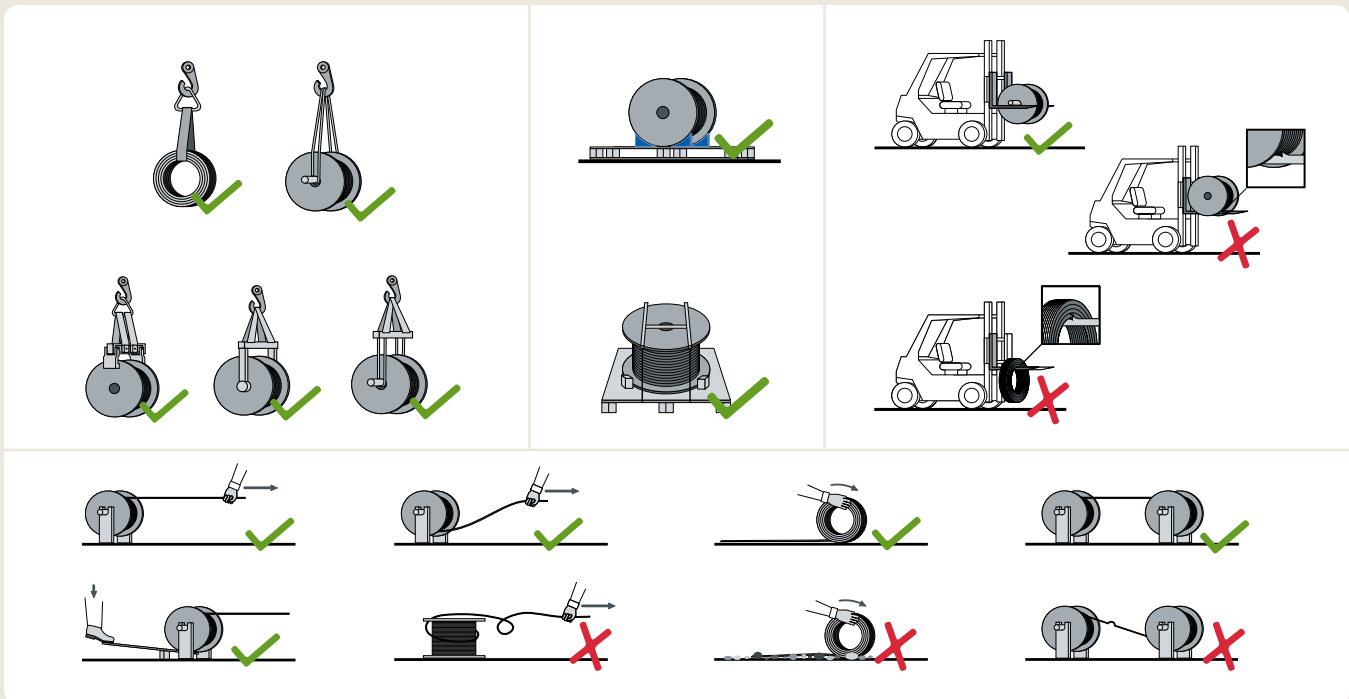

At all times, contact of the rope with any metallic pieces should be avoided to prevent early damage.



**EWRIS**  
European Federation of Steel Wire Rope Industries



All information in this promotional material shall illustrate products and services in a non final way and invite to further technical or commercial explanation; they are not contractual. © ArcelorMittal 2018.

High performance **Hoisting Ropes**  
for the most demanding environments

ArcelorMittal ROPES, 25 Avenue de Lyon, BP 38, F-01002 Bourg-en-Bresse Cedex  
Telephone: +33 4 74 32 82 12 | Fax: +33 4 74 32 81 05 | Email: [lifting.ropes@arcelormittal.com](mailto:lifting.ropes@arcelormittal.com)

[www.arcelormittal.com/wireropes](http://www.arcelormittal.com/wireropes)

**ArcelorMittal ROPES**  
ENGINEERING EXCELLENCE